

# Product Data Sheet

P/N : S+IOX

**S+IOX**  
Oxygen Sensor (O<sub>2</sub>)

**Introduction** The S+IOX-1 is a partial pressure O<sub>2</sub> sensor for use in medical oxygen analysers including anaesthesia equipment

**Key Features:** Highly stable, 0-100% measurement range, on-board temperature compensation

Performance Characteristics	
Output signal	9-13mV in Air @STP
Zero Current (uV)	< 0.25uV
T90 Response Time	<15 seconds
Expected LifeSignal in 100%O <sub>2</sub>	100%±1%O <sub>2</sub>
Measurement Range	0 - 100% Oxygen
Temperature Compensation (20-40°C)	<2%O <sub>2</sub>
Linearity	Linear
Recommended Load Resistor	Min 10KOhms

Environmental Details	
Temperature Range Continuous	-20°C to +50°C
Pressure Range	500 to 2000 mbar
Operating Humidity Range	0-99% non condensing

**Important Note:**

All performance data is based on conditions at 20°C, 50%RH and 1 atm, using DD Scientific recommended circuitry.

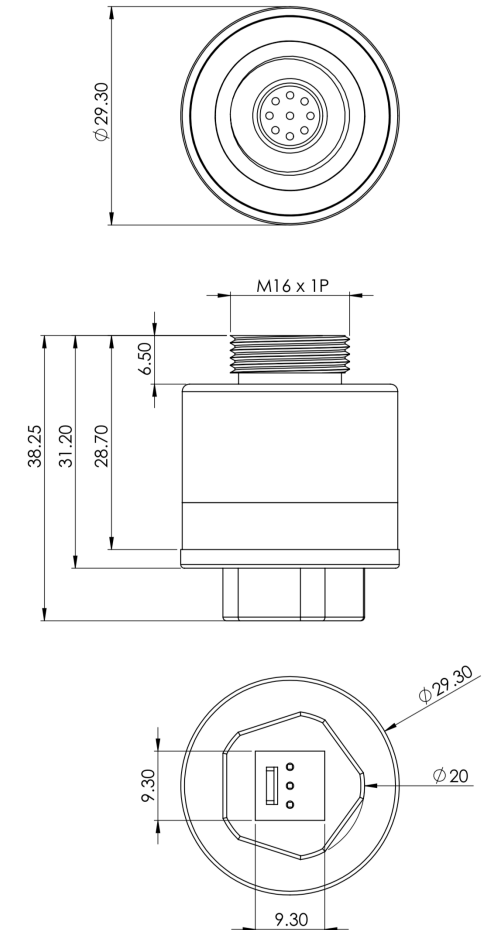

Lifetime Details	
Long Term Output Drift	< 5% per annum
Recommended Storage Temp	0°C to 20°C
Expected Operating Life	1.6m%O <sub>2</sub> hrs in AIR STP
Standard Warranty	12 months from date of dispatch

Intrinsic Safety Data	
Maximum current in normal operation (pure O <sub>2</sub> )	0.01 A
Maximum o/c Voltage (10 to 100% O <sub>2</sub> )	0.9 V
Maximum s/c Current (10 to 100% O <sub>2</sub> )	0.5 A

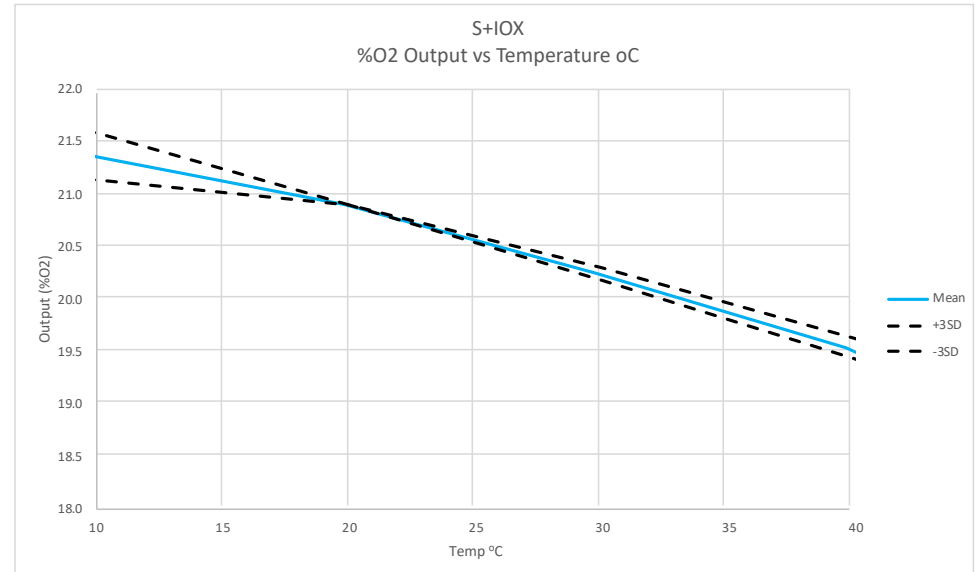

### Cross Sensitivity Data

Toxic gases at TLV levels will have no cross-sensitivity effect on DD-Scientific oxygen sensors. At very high levels (i.e. percent levels), highly oxidising gases (e.g. ozone, chlorine) will interfere to the extent of their oxygen equivalent, but most other commonly occurring gases will have no effect.

### Acid Gases

**IMPORTANT NOTE:** Acid gases such as CO<sub>2</sub> and SO<sub>2</sub> will be absorbed by the electrolyte and tend to increase the flux of oxygen to the electrode. This gives an enhanced oxygen signal of approximately 0.3% of signal per 1% CO<sub>2</sub>. DD-Scientific oxygen sensors are not suitable for continuous operation in concentrations of CO<sub>2</sub> above 25%.

**WARNING:** By the nature of the technology used, any electrochemical gas sensor offered by DD Scientific can potentially fail to meet specification without warning. Although DD Scientific Ltd makes every effort to ensure the reliability of our products of this type, where life safety is a performance requirement of the product, we recommend that all sensors and instruments using these sensors are checked for response to gas before use.

Every effort has been made to ensure the accuracy of this document at the time of printing. In accordance with the company's policy of continued product improvement DD SCIENTIFIC Limited reserves the right to make product changes without notice. No liability is accepted for any consequential losses, injury or damage resulting from the use of this document or from any omissions or errors herein. The data is given for guidance only. It does not constitute a specification or an offer for sale. The products are always subject to a program of improvement and testing which may result in some changes in the characteristics quoted. As the products may be used by the client in circumstances beyond the knowledge and control of DD SCIENTIFIC Limited, we cannot give any warranty as to the relevance of these particulars to an application. It is the clients' responsibility to carry out the necessary tests to determine the usefulness of the products and to ensure their safety of operation in a particular application. Performance characteristics on this data sheet outline the performance of newly supplied sensors. Output signal can drift below the lower limit over time.